



## Hydronix Moisture Sensor Electrical Installation Guide



To re-order quote part number:	HD0678
Revision:	1.9.0
Revision date:	March 2026

## Copyright

Neither the whole or any part of the information contained in nor the product described in this documentation may be adapted or reproduced in any material form except with the prior written approval of Hydronix Limited, hereinafter referred to as Hydronix.

© 2026

Hydronix Limited  
Units 11-12,  
Henley Business Park  
Pirbright Road  
Normandy  
Guildford  
Surrey  
GU3 2DX  
United Kingdom

Company Number: 01609365 | VAT Number: GB384155148

All rights reserved

### CUSTOMER RESPONSIBILITY

The customer in applying the product described in this documentation accepts that the product is a programmable electronic system which is inherently complex and which may not be completely free of errors. In doing so the customer therefore undertakes responsibility to ensure that the product is properly installed commissioned operated and maintained by competent and suitably trained persons and in accordance with any instructions or safety precautions made available or good engineering practice and to thoroughly verify the use of the product in the particular application.

### ERRORS IN DOCUMENTATION

The product described in this documentation is subject to continuous development and improvement. All information of a technical nature and particulars of the product and its use including the information and particulars contained in this documentation are given by Hydronix in good faith.

Hydronix welcomes comments and suggestions relating to the product and this documentation

### ACKNOWLEDGEMENTS

Hydronix, Hydro-Probe, Hydro-Mix, Hydro-Skid, Hydro-View and Hydro-Control are Registered Trade Marks of Hydronix Limited

### CUSTOMER FEEDBACK

Hydronix is continually looking to improve not only its products but also the services that we offer to our customers. If you have any suggestions about how we can do this or if you have any other feedback that would be helpful please complete our short form at [www.hydronix.com/contact/hydronix\\_feedback.php](http://www.hydronix.com/contact/hydronix_feedback.php).

If your feedback is concerning an Atex certified product or associated service it would be very helpful for you to give us your contact details and the model number and serial number of the product if possible. This will enable us to contact you with any relevant safety advice should this be necessary. It is not obligatory to leave your contact details and any information will be treated as confidential.

## ***Hydronix Offices***

### **UK Head Office**

Address: Units 11-12,  
Henley Business Park  
Pirbright Road  
Normandy  
Surrey  
GU3 2DX

Tel: +44 1483 468900

Email: [support@hydronix.com](mailto:support@hydronix.com)  
[sales@hydronix.com](mailto:sales@hydronix.com)

Website: [www.hydronix.com](http://www.hydronix.com)

### **North American Office**

Covers North and South America, US territories, Spain and Portugal

Address: 692 West Conway Road  
Suite 24, Harbor Springs  
MI 47940  
USA

Tel: +1 888 887 4884 (Toll Free)  
+1 231 439 5000

Fax: +1 888 887 4822 (Toll Free)  
+1 231 439 5001

### **European Office**

Covers Central Europe, Russia and South Africa

Tel: +49 2563 4858  
Fax: +49 2563 5016

### **French Office**

Tel: +33 652 04 89 04



## ***Revision history***

<b>Revision No</b>	<b>Date</b>	<b>Description of Change</b>
1.0.0	Feb 2015	First Release
1.1.0	May 2015	Sensor Cable Product Number Changed
1.2.0	March 2016	Sensor Interface References updated
1.3.0	March 2017	Non-Mil Spec Sensor details added (Change to permanently wired sensor details added)
1.4.0	Nov 2017	Update sensor Model Numbers
1.5.0	Dec 2021	Cable Specification Address update
1.6.0	Feb 2022	Added I/O Protection section Terminating Resistor installation added
1.7.0	Jan 2023	Added Hydro-Probe BX and CA Moisture Probe. Updated Terminating resistor installation to include use of 0975AT cable
1.7.1	Jan 2024	Special conditions of use section added
1.8.0	Sep 2025	RS485 network topology, terminating resistors and appropriate grounding information clarification. Revised sections and subsections layout
1.9.0	March 2026	Added Cyber Security, Radio Interference, and Disposal information sections.



## **Table of Contents**

Chapter 1 Electrical Installation .....	11
1 Introduction.....	11
2 Special Conditions of Use .....	12
3 Installation Guidelines .....	12
4 Analogue Outputs.....	13
5 Sensor Cable Connections .....	14
6 RS485 Multi-Drop Connection .....	15
7 Terminating Resistor and 0975AT Cable .....	16
8 Ground and Cable Shield Connections.....	16
9 Digital Input/Output Connection .....	17
10 Connecting the Sensor Cable to Rotating Connector (Orbiter).....	18
Chapter 2 Communications.....	21
1 Connecting to a PC .....	21
Appendix A Document Cross Reference .....	25
1 Document Cross Reference .....	25



## ***Table of Figures***

Figure 1: 0975A Sensor Cable Connections.....	14
Figure 2: RS485 Multi-Drop Network topology .....	15
Figure 3: RS485 Multi-Drop Connections .....	15
Figure 4: Terminating Resistor and 0975AT Cable Placement – Multi-Sensor Network.....	16
Figure 5: Terminating Resistor and 0975AT Cable Placement – Single Sensor Application .....	16
Figure 6: Internal/External Excitation of Digital Input 1 & 2 .....	17
Figure 7: Activation of Digital Output 2 .....	17
Figure 8: I/O Protection .....	18
Figure 9: Sensor Connections for all types of Rotating Connector.....	18
Figure 10: Wiring Diagram .....	19
Figure 11: RS232/485 Converter Connections (0049B).....	21
Figure 12: RS232/485 Converter Connections (0049A).....	21
Figure 13: RS232/485 Converter connections (Sensor Interface Module).....	22
Figure 14: Ethernet Adapter Connections (EAK01).....	22
Figure 15: Ethernet Power Adapter Kit Connections (EPK01) .....	23



## 1 Introduction

This Electrical Installation guide is valid for the following Hydronix sensors only:

Hydro-Probe	(Model number HP04 onwards)
Hydro-Probe XT	(Model number HPXT02 onwards)
Hydro-Probe Orbiter	(Model number ORB3 onwards)
Hydro-Probe SE	(Model number SE03 onwards)
Hydro-Mix	(Model number HM08 onwards)
Hydro-Mix HT	(Model Number HMHT01 onwards)
Hydro-Mix XT	(Model Number HMXT01 onwards)
Hydro-Probe BX	(Model Number HPBX01 onwards)
CA Moisture Probe	(Model Number CA0022)

User guides for other model numbers are available for download from the Hydronix website: [www.hydronix.com](http://www.hydronix.com)



## 2 Special Conditions of Use

- The user shall provide for the required cable strain relief to protect the MIL spec connector/cable gland
- Only power supplies that are classified as Class 2 and Class II shall be used with this sensor.
- Class II PSU is to be double insulated and have a limited energy protection.
- The external power supply rated 24vDC or 15 to 30vDC shall be isolated and be for the rated DC Voltage.

### 2.1 Cyber Security

To report a potential security vulnerability or incident related to Hydronix products, please contact [security@hydronix.com](mailto:security@hydronix.com). This ensures compliance with EU 2024/2847 reporting obligations.

### 2.2 Radio Interference

This equipment generates and uses radio frequency energy and may cause interference to radio communications if not installed and used in accordance with these instructions. These devices comply with Part 18 of the FCC rules.

### 2.3 Disposal

Do not dispose of this equipment with general/household waste. This equipment must be recycled in accordance with local/regional/national Waste Electrical and Electronic Equipment (WEEE) regulations.

## 3 Installation Guidelines

### 3.1 Mil Spec Connector Sensors

Hydronix supplies cable 0975A for use with these sensors and it is available in different lengths. Any extension cable required should be connected to the Hydronix sensor cable using a suitable screened junction box. The sensor is directly backward compatible with older 0090A cables (as used with the previous versions of Hydronix Moisture Sensors). When connecting to a 0090A cable it is not possible to use the 2<sup>nd</sup> analogue output provided by the sensor.

For installations using both Analogue Outputs, it is necessary to use Sensor Cable part number 0975A.

It is recommended to allow the sensor to stabilise for 15 minutes after applying power before use.

### 3.2 Permanently Wired Sensors

Some Hydronix sensors do not utilise the Mil spec connector as supplied with the 0975A cable. These sensors are supplied with a factory fitted permanent cable. However, all cable specifications and connection methods for permanently wired sensors as detailed in this guide are identical to the 0975A cable.

### 3.3 Cable Specification

- Six pairs twisted (12 cores total) screened (shielded) cable with 22 AWG, 0.35mm<sup>2</sup> conductors.
- Screen (shield): Braid with 65% minimum coverage plus aluminium/polyester foil.

- Recommended cable types: Belden 8306, Alpha 6377
- Maximum cable run: 100m, separate to any heavy equipment power cables.

### 3.4 Cabling Requirements

- Ensure that the cable is of a suitable quality
- Ensure that the RS485 cable is taken back into the control panel. This can be used for diagnostic purposes and takes the minimum of effort and cost to connect at the time of installation.
- Route the signal cable away from any power cables.
- Check that the installation is properly grounded.
- The cable must **only** be grounded at the sensor end.
- Ensure that the cable screen (shield) is **not** connected at the control panel.
- Ensure that there is continuity of the screen (shield) through any junction boxes.
- Keep the number of cable joins to a minimum.

## 4 Analogue Outputs

Two DC current sources generate analogue signals proportional to separately selectable parameters (e.g. filtered Unscaled, filtered moisture, average moisture, etc). See Configuration guide HD0679 for further details. Using the Hydro-Com software or direct computer control, the output may be selected to be:

1. 4-20 mA
2. 0-20 mA - 0-10 V output can be achieved using the 500 Ohm resistor supplied with the sensor cable.

## 5 Sensor Cable Connections

Twisted Pair Number	MIL spec pins	Sensor connections	Cable colour
1	A	+15-30V DC	Red
1	B	0V	Black
2	C	1 <sup>st</sup> Digital input	Yellow
2	--	-	Black (Cut back)
3	D	1 <sup>st</sup> Analogue Positive (+)	Blue
3	E	1 <sup>st</sup> Analogue Return (-)	Black
4	F	RS485 A	White
4	G	RS485 B	Black
5	J	2 <sup>nd</sup> Digital input	Green
5	--	-	Black (Cut back)
6	K	2 <sup>nd</sup> Analogue Positive (+)	Brown
6	E	2 <sup>nd</sup> Analogue Return (-)	Black
	H	Screen	Screen

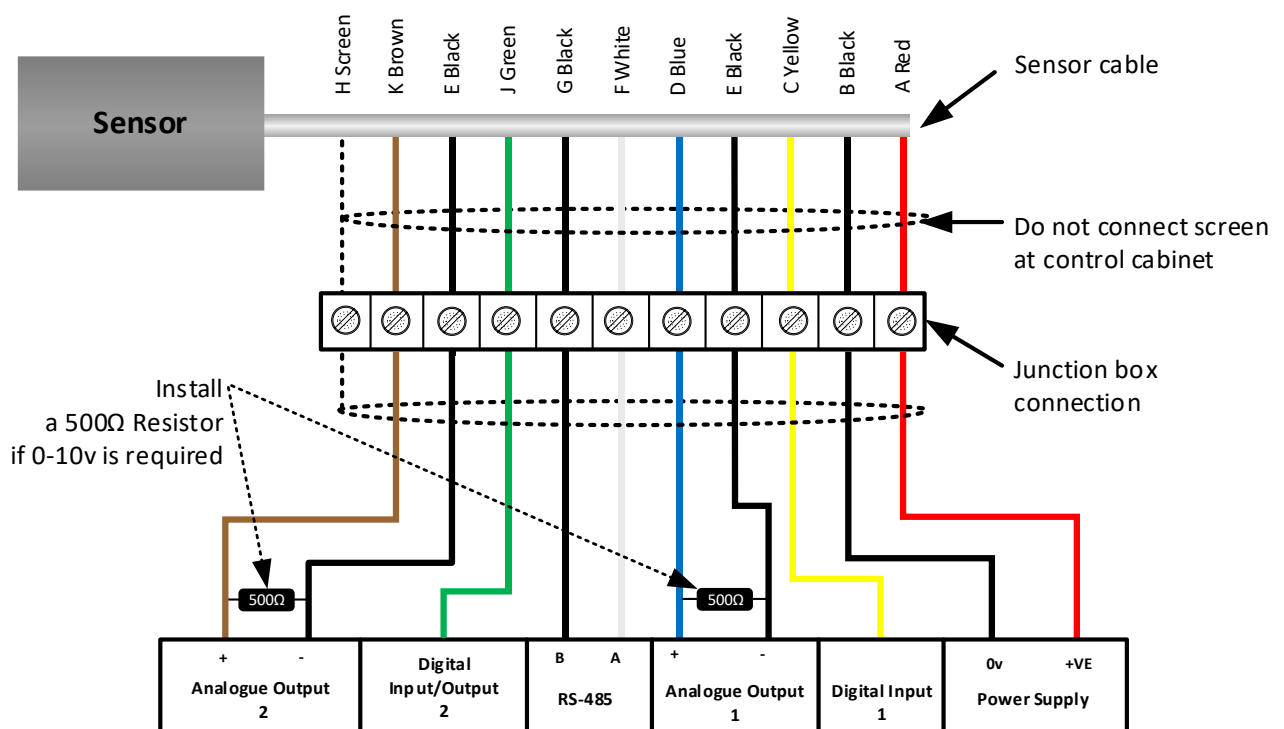

Figure 1: 0975A Sensor Cable Connections

**Note:** The sensor's body should not be relied upon as an appropriate grounding connection (for more details, see section 8).

## 6 RS485 Multi-Drop Connection

The RS485 serial interface allows up to 16 sensors to be connected together via a multi-drop network. Each sensor should be connected using a waterproof junction box.

When connecting two or more sensors to one master device, they must be wired in a Multi-Drop network topology, otherwise known as Daisy-Chain (see Figure 2).

The maximum network length must not exceed 100m.

The maximum node distance (Junction Box to sensor) must not exceed 4m, except for the Junction Box furthest from the master device.

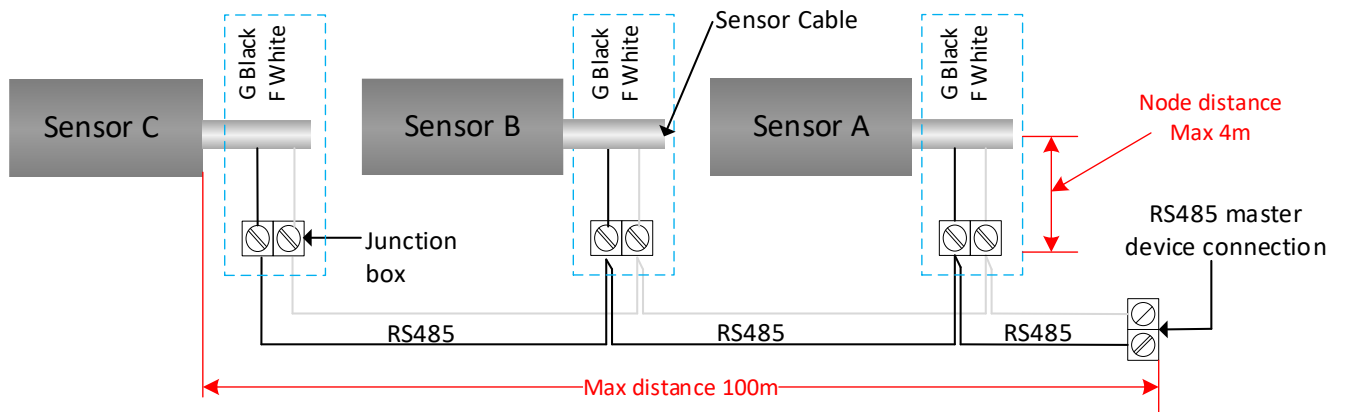

Figure 2: RS485 Multi-Drop Network topology

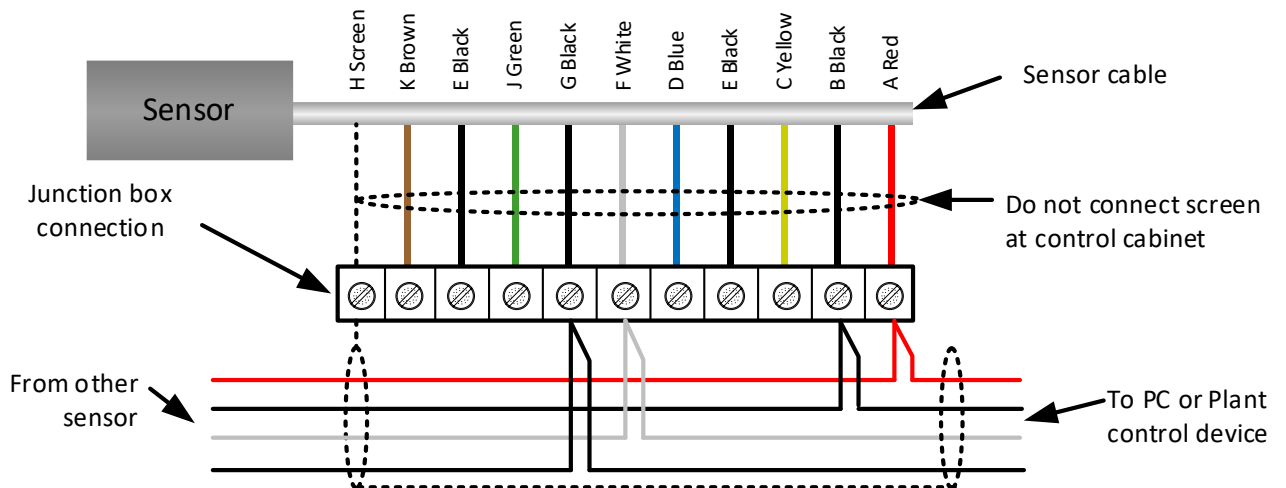

Figure 3: RS485 Multi-Drop Connections

## 7 Terminating Resistor and 0975AT Cable

To avoid data-corrupting reflections a 0975AT cable should be used to connect the last node of the network.

**NB: If there is only one node then an 0975AT cable should be used.**

A 120Ω resistor should be placed at the RS485 Master.

When multiple sensors are connected, or long cable lengths are used, a Terminating Resistor and 0975AT can be used to improve the communication stability. Terminating the RS485 involves adding resistors at each end of the network. The 0975AT cable has a built in 120 Ω resistor. A 120Ω resistor (distributed with the 0975AT cable) should be used at the RS485 master. All other sensors must remain unterminated.

For permanently wired sensors the end-of-network resistor must be installed in the Junction box of the last sensor in the network.

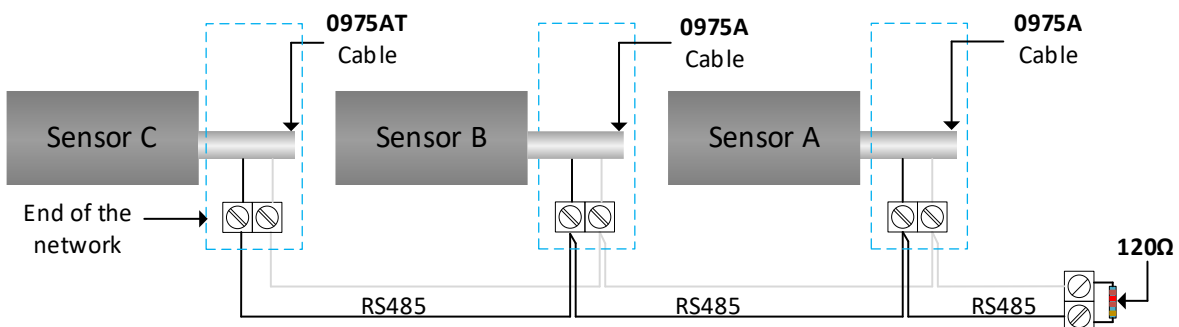

Figure 4: Terminating Resistor and 0975AT Cable Placement – Multi-Sensor Network

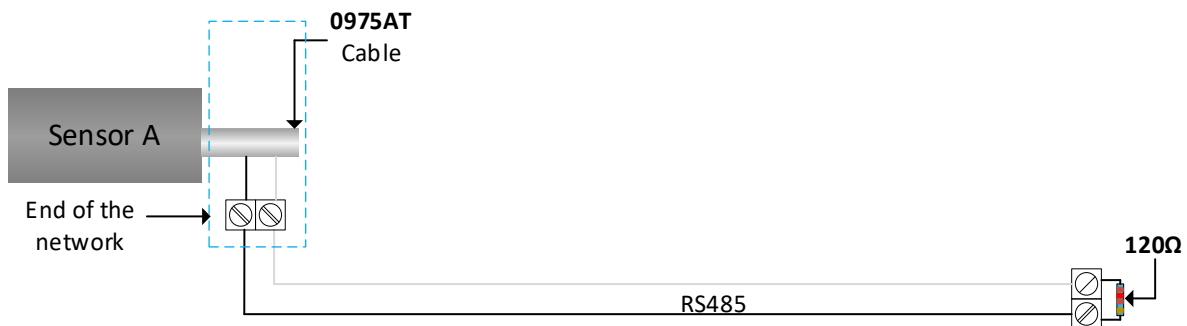

Figure 5: Terminating Resistor and 0975AT Cable Placement – Single Sensor Application

## 8 Ground and Cable Shield Connections

Do not use the sensor body as a grounding connection.

Do not connect cable screen (shield) at the control panel.

The earthing connection must be made using the sensor's grounding terminal or the cable screen (shield) in the nearest Junction Box.

All sensor cables' screens (shields) must be connected to form continuity throughout the entire network.

Earth connection must ground to a single earth point to prevent earth loops forming

Ensure equipotential bonding of all exposed metalwork.

In high lightning risk areas, install adequate surge and lightning protection.

## 9 Digital Input/Output Connection

The sensor has two digital inputs, the second of which can also be used as an output for a known state. Full descriptions of how the digital inputs/output can be configured are included in the configuration guide HD0679. The most common use of the digital input is for batch averaging, where it is used to indicate the start and end of each batch. This is recommended as it provides a representative reading of the full sample during each batch.

An input is activated using 15 – 30vDC into the digital input connection. The sensor power supply may be used as an excitation supply for this, or alternatively an external source may be used as shown below.

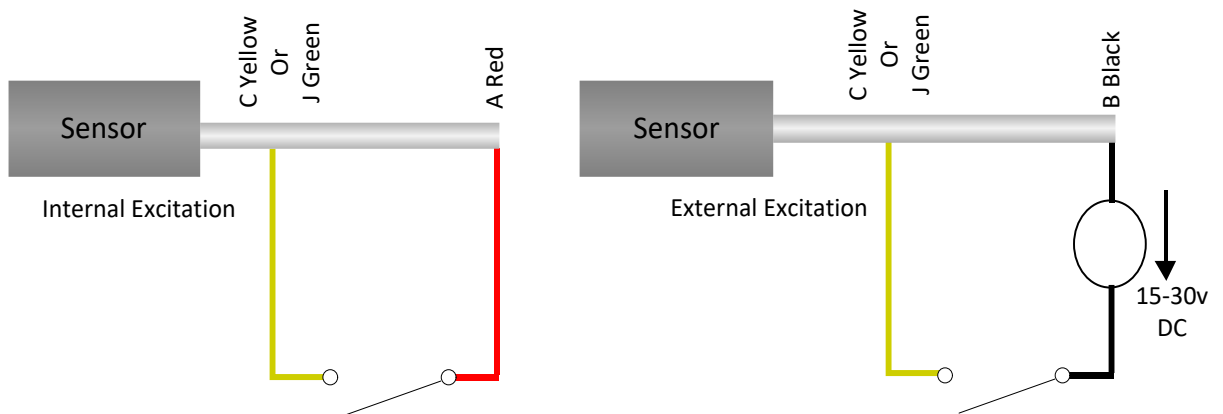

Figure 6: Internal/External Excitation of Digital Input 1 & 2

When the digital output is activated, the sensor electronically switches pin J to 0V. This can be used to switch a relay for a signal, for example ‘bin empty’. Note that the maximum current sink in this case is 500mA and in all cases over current protection should be used.

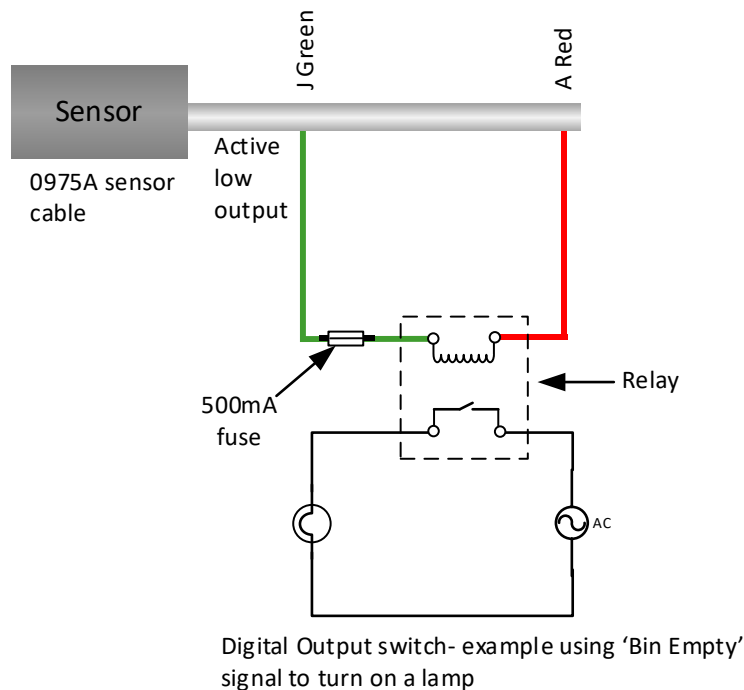

Figure 7: Activation of Digital Output 2

## 9.1 Digital I/O protection

Back electromotive force (Back EMF), also known as counter-electromotive force, is the electromotive force that opposes the change in current through a conductor. When current passes through a coil, such as an inductor, relay coil, motor or solenoid winding, energy is stored in the form of a magnetic field around the coil. When power is removed from the circuit, the magnetic field collapses producing a large reverse voltage spike which can damage sensitive components in the circuit such as transistors and diodes.

It is recommended that a “fly-wheel” diode is connected across any inductive load that is connected to the inputs or outputs of the sensor. This diode will suppress the back EMF voltage spike, protecting the inputs from damage. The recommended diode for this protection is a 1N4007 or equivalent. It should be connected as shown in Figure 8.

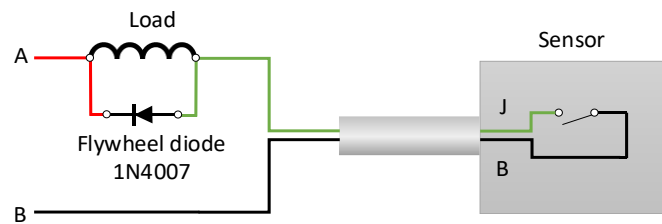

Figure 8: I/O Protection

## 10 Connecting the Sensor Cable to Rotating Connector (Orbiter)

### 10.1 Wiring for all Rotating Connector Types

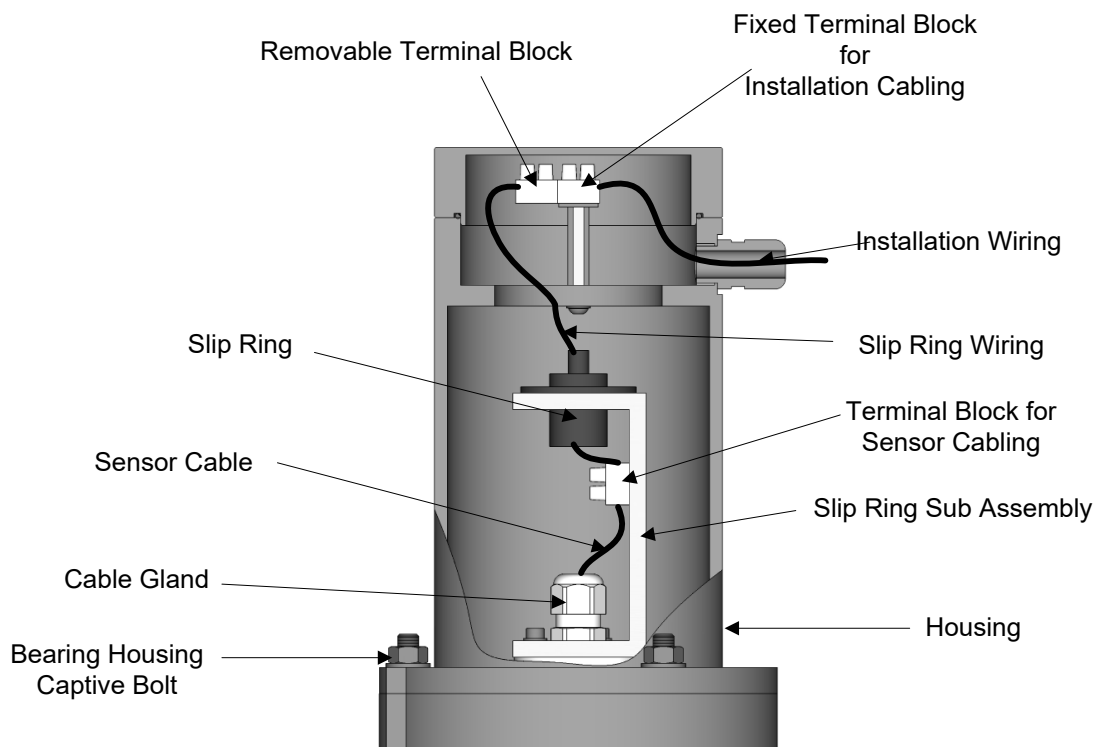

Figure 9: Sensor Connections for all types of Rotating Connector.

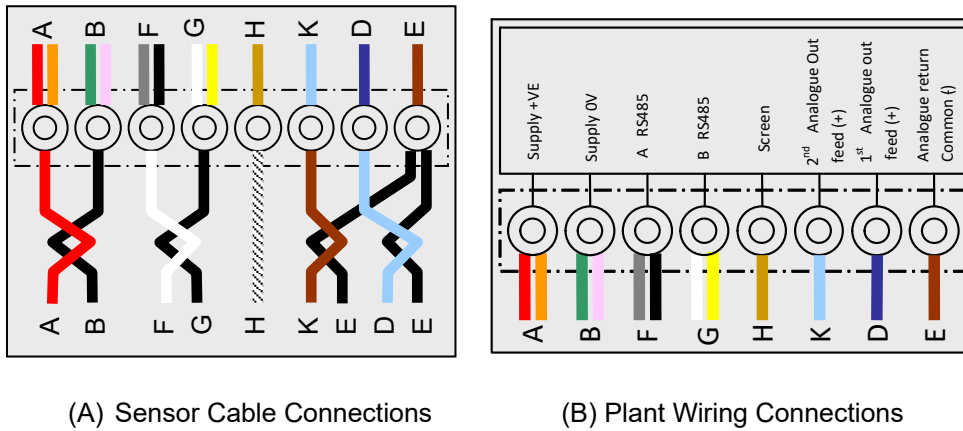

Figure 10: Wiring Diagram

Connection Port	Slip Ring Wire Colour	Sensor Wire Colour	Connection Type
A	Red/Orange	Red	Supply +VE
B	Green/Mauve	Black	Supply 0V
F	Grey /Black	White	A RS485
G	White/Yellow	Black	B RS485
H	Khaki	Screen	Screen
K	Light blue	Brown	2 <sup>nd</sup> analogue (+)
D	Dark blue	Light Blue	1 <sup>ST</sup> Analogue (+)
E	Dark brown	Black (From both analogue circuits)	Analogue return Common (-)

Table 1: Sensor cable to Slip Ring connections

### 10.2 Connection - Rotating Connector Type “A”

- With the cable connected to the Hydro-Probe Orbiter and the Rotating Connector Housing removed, feed the cable up through the rotating shaft and Slip Ring Sub-Assembly gland and cut to the correct length. Ensure the cable and its protective hose do not interfere with the mixer arms. Tighten the gland.
- Cut back the cable sheath and crimp on bootlace ferrules. 8 conductors are required, unused conductors should be cut back.
- Connect to the terminals as per the diagram in the Rotating Connector (see Figure 10).
- Install the housing over the slip ring sub assembly and bolt down using the bearing housing captive bolts.

- Feed the installation cabling through the housing cable gland and cut to length. Wire the installation cable to the fixed terminal block as per the diagram in the lid (see Figure 10). Connect the removable terminal block plug from the slip ring sub-assembly.
- Fit the Rotating Connector lid and screw down.

### **10.3 Connection - Rotating Connector Type “B”**

- With the cable connected to the Hydro-Probe Orbiter and the Rotating Connector Housing removed, feed the cable up through the cable gland and cut to the correct length.
- Cut back the cable sheath and crimp on bootlace ferrules. 8 conductors are used so any unused conductors should be cut back
- Connect to the terminals as per the diagram in the Rotating Connector (see Figure 10).
- Install the housing over the slip ring sub assembly and bolt down using the bearing housing captive bolts.
- Feed the plant cabling through the housing cable gland and cut to length. Wire the plant cable to the fixed terminal block as per the diagram in the lid (see Figure 10).
- Connect the removable terminal block plug from the slip ring sub-assembly.
- Fit the Rotating Connector lid and screw down.

# 1 Connecting to a PC

A converter is required to connect the RS485 interface to a PC. Up to 16 sensors may be connected at any time.

**Note: All sensors are set to address 16 as default. If more than one sensor is to be connected to a control system using the RS485 or to Hydronix Hydro-Com software all sensor address numbers must be different. See appropriate Hydro-Com user guide for more details.**

It is highly recommended that the RS485 signals be run to the control panel even if they are unlikely to be used as this will facilitate the use of diagnostic software should the need arise.

There are four types of converter supplied by Hydronix.

## 1.1 RS232 to RS485 Converter – D Type (part no: 0049B)

Manufactured by KK systems, this RS232 to RS485 converter is suitable for connecting up to six sensors on a network. The converter has a terminal block for connecting the twisted pair RS485 A and B wires. The converter can then be connected directly in to the PC serial communication port.

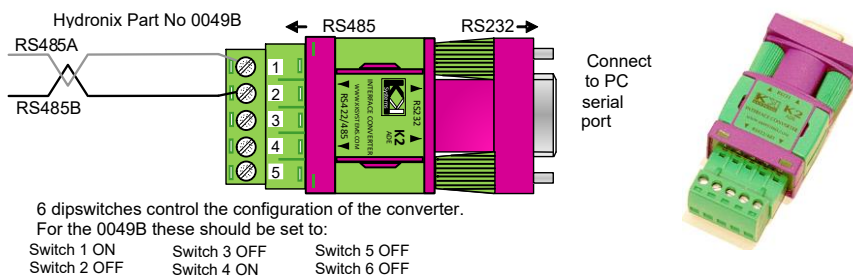

Figure 11: RS232/485 Converter Connections (0049B)

## 1.2 RS232 to RS485 Converter – DIN Rail Mounting (part no: 0049A)

Manufactured by KK systems, this powered RS232 to RS485 converter is suitable for connecting up to 16 sensors on a network. The converter has a terminal block for connecting the twisted pair RS485 A and B wires. The converter can then be connected to a PC serial communication port.

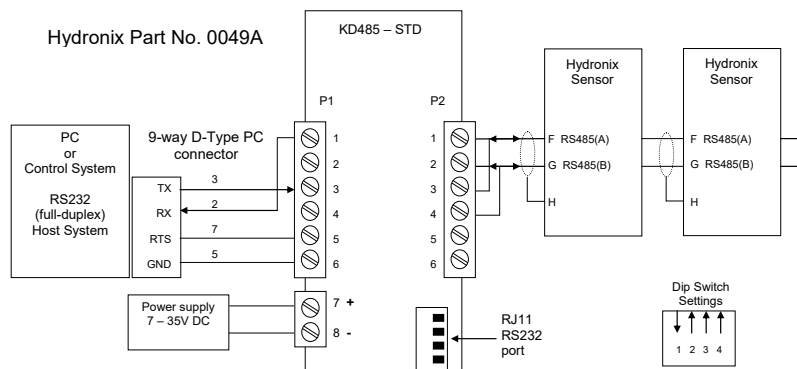

Figure 12: RS232/485 Converter Connections (0049A)

### 1.3 USB Sensor Interface Module

Manufactured by Hydronix, this USB-RS485 converter is suitable for connecting up to 16 sensors on a network. The converter has a terminal block for connecting the twisted pair RS485 A and B wires. The converter can then be connected to a USB port. The Sensor Interface Module is powered from the USB port. If sensor power is required the external 24v power supply can be used. See USB Sensor Interface Module User Guide (HD0303) for further information.

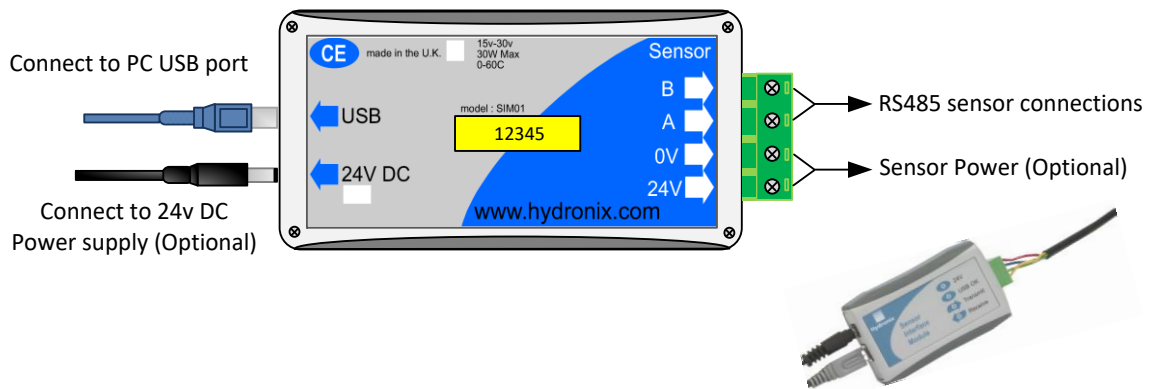

Figure 13: RS232/485 Converter connections (Sensor Interface Module)

### 1.4 Ethernet Adapter Kit (part no: EAK01)

Manufactured by Hydronix, the Ethernet adapter is suitable for connecting up to 16 sensors to a standard Ethernet network. An optional Ethernet Power Adapter Kit (EPK01) is also available which eliminates the need for additional expensive cables to be run to a remote location which does not have local power. If this is not used then the Ethernet adapter will require a local 24v power supply.

Hydronix Part No: EAK01

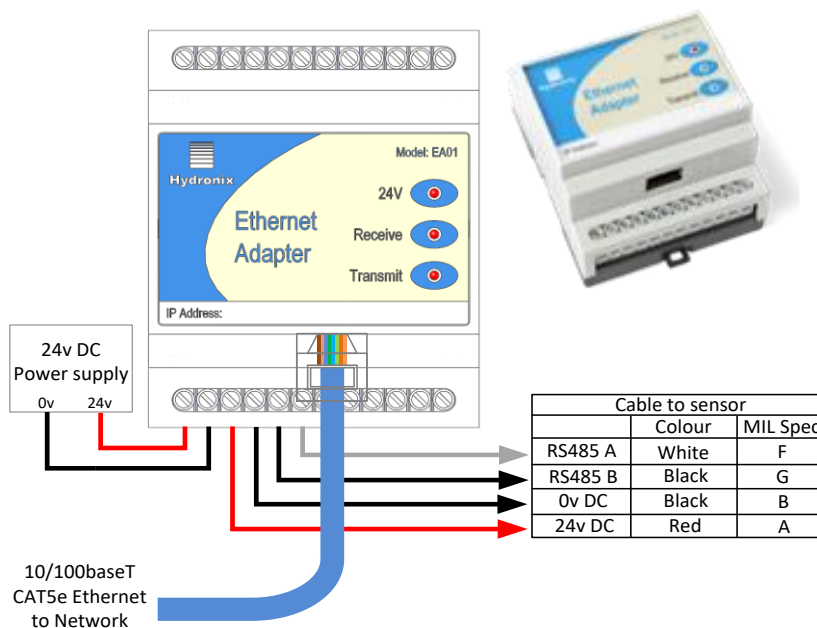

Figure 14: Ethernet Adapter Connections (EAK01)

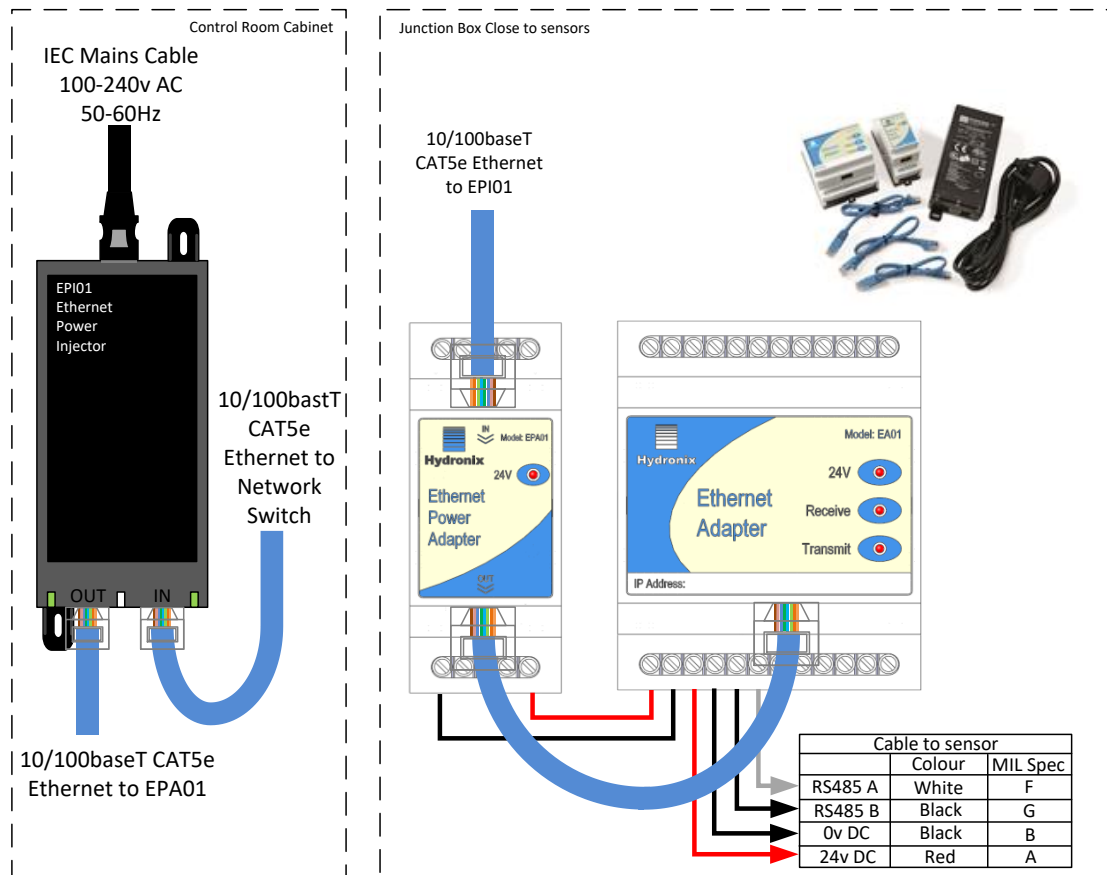

Figure 15: Ethernet Power Adapter Kit Connections (EPK01)



## 1 Document Cross Reference

This section lists all of the other documents that are referred to in this User Guide. You may find it beneficial to have a copy available when reading to this guide.

<b>Document Number</b>	<b>Title</b>
HD0682	Hydro-Com User Guide
HD0303	Sensor Interface Module User Guide
HD0679	Hydronix Microwave Moisture Sensor Configuration and Calibration Guide



## ***Index***

Activation of digital output .....	17	Digital Input .....	17
Analogue Output .....	13	Digital Output .....	17
Cable .....	13	Excitation of digital input .....	17
Cable specification .....	12	Hydro-Com.....	13
Cabling recommendations .....	13	Installation	
Connection		Electrical.....	13
digital input/output .....	17	Junction Box .....	15
Multi-Drop.....	15	Output	
PC.....	21	Analogue.....	13
Connector		Rotating connector.....	18
Hard Wired .....	12	RS232/485 Converter .....	21
MIL-Spec .....	14	Sensor Cable .....	14
Converter		USB Sensor Interface Module .....	22
RS232/485 .....	21		