



Digital Microwave Sensor for Measuring
Moisture or Dissolved Solids

Hydro-Probe SE



THE ORIGINAL – THE LEADERS – THE BEST

Hydro-Probe SE

Microwave sensor for moisture or dissolved solids

The Hydro-Probe SE is a high temperature microwave sensor designed for use in liquids such as concentrates, solutions or any process where the level of dissolved solids requires measurement.

The sensor is manufactured from materials that are safe for food contact enabling installation in food production or similar environments. Typical applications include measuring in an evaporator when reducing liquids or any process where an exact measurement of moisture in a liquid is required.



Features

- Designed for installation in a pressurised environment.
- Digital technology provides precise linear moisture measurement.
- Choice of measurement modes for optimising sensor performance in a variety of applications and material types.
- Advanced Digital Signal Processing provides a clear signal with rapid response.
- Averaging and signal smoothing functions.
- Configurable digital input / outputs.
- Configurable alarms.
- Fast response to changing conditions with 25 measurements per second.
- Consistent performance with no need for recalibration except for use with different materials.
- Stand alone or simple integration into a new or existing automation system.
- Not affected by dust or colour.

Display and Control Options

Hydronix has a range of display and control options

10 Hydro-Mix Raw Dissolved Mode F	10 Hydro-Mix Raw Dissolved Mode V	10 Hydro-Mix Raw Dissolved Mode F
20.49	21.31	20.64
10 Hydro-Mix Filtered Moisture Mode F	10 Hydro-Mix Filtered Moisture Mode V	10 Hydro-Mix Filtered Moisture Mode B
19.4	100.0	71.13

Configure and Calibrate

Easily configure and calibrate the sensor using Hydro-Com Software

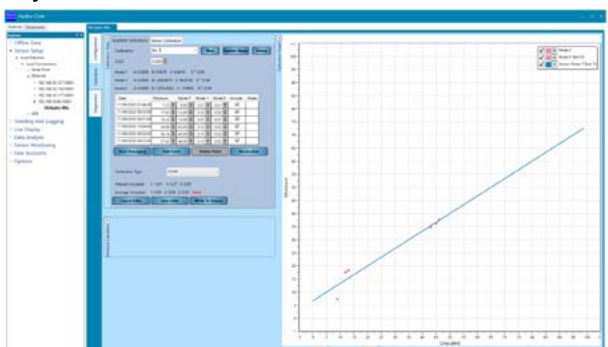

Connectivity

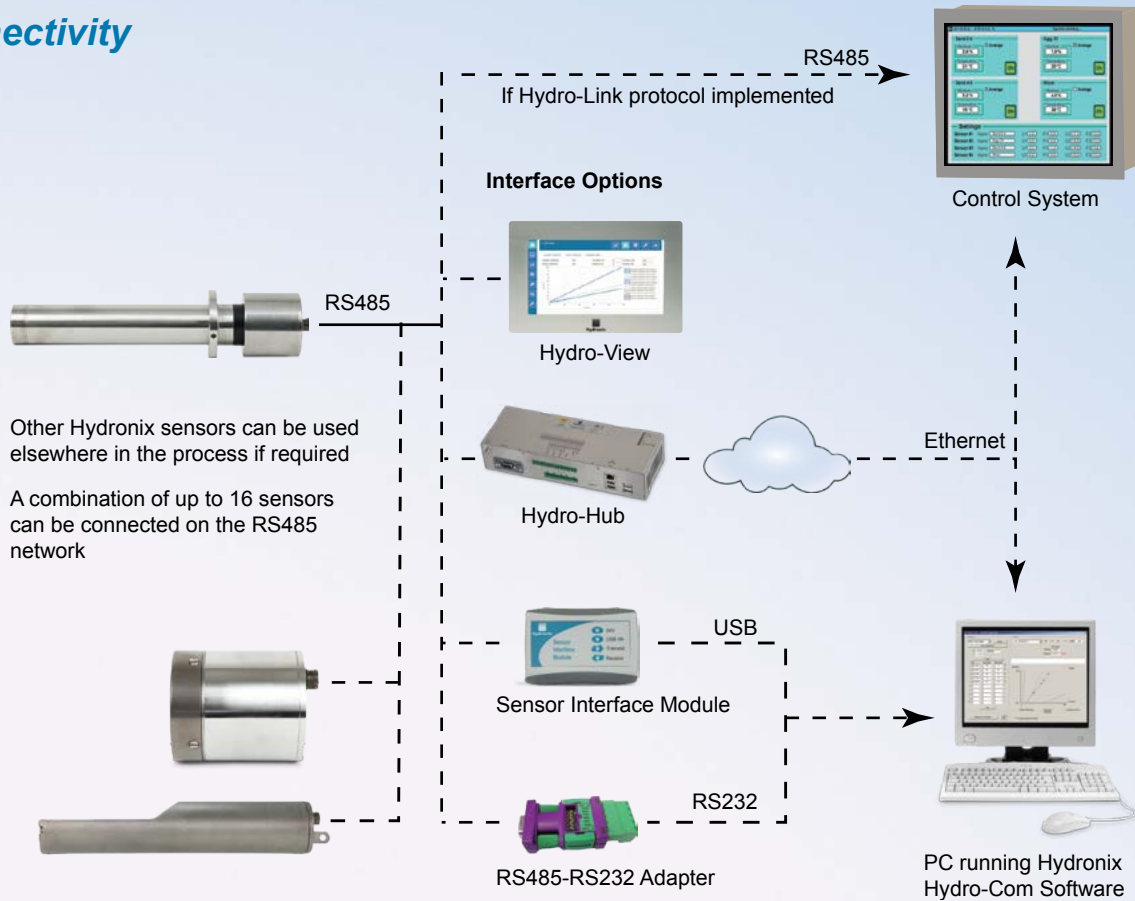

Typical Applications:

Hydronix sensors can be used in many industries that require moisture to be measured before further processing takes place. Typical examples include applications that use a Calandria or a spray dryer.



Reducing Liquids

The concentration of a liquid in an evaporation process can be measured.



Oils

Moisture can be measured in many organic oils including vegetable and olive oil.



Alcohol

The sensor can measure moisture levels in alcohols during processing.



Waste Processing

The concentration of solids can be measured during the processing of biological waste.

Typical Installations

The Hydro-Probe SE can be mounted into a vessel or pipeline.

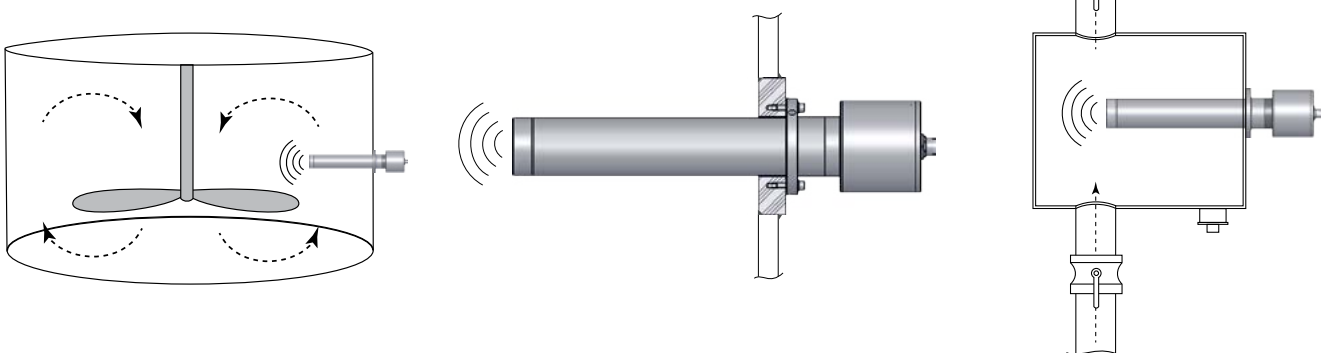

Technical Information

Construction

Body: 316 Stainless Steel.
Faceplate: Ceramic.
O-Rings: EPDM.

Fixing

The sensor must be placed in the flow of material and is attached to the vessel using the bolted flange.

Measurement Range

Moisture: 0-100%, material dependant.
Brix: >50° Bx.

Penetration of Field

Approximately 75-100mm, material dependant.

Operating Temperature

Materials Section: 0 to 120°C.
Electronics Section: 0 to 60°C.
The sensor will not measure ice.

Refresh Rate

25 times per second.

Analogue Outputs

Two configurable 4-20mA or 0-20mA current loop source available for Unscaled, moisture, Brix or material temperature.

Digital (Serial) Communication

Opto-Isolated RS485 2-wire port. RS232, Ethernet and USB adaptors available.

Programming details to access sensor values and parameters are available on request.

Discrete Input/Output

One discrete input, one discrete I/O.

Environmental

Pressure: Full vacuum to 5 Bar gauge.
Electronics Section Protection: IP67.

Extension Cable

Up to six twisted pairs, 22AWG, 0.35mm² conductors. Screen braid with 65% minimum coverage plus aluminium/polyester foil. 100m maximum cable.

Power Supply

+15V to +30V DC, 200mA max operating, 1 Amp startup.

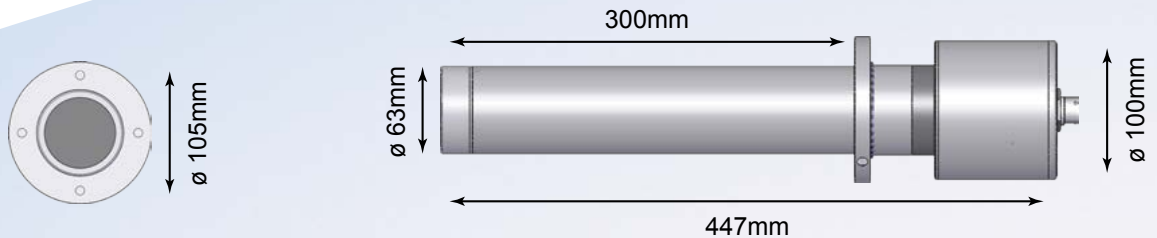

Hydronix

Head Office - United Kingdom:

Tel: +44 (0)1483 468900

Email: enquiries@hydronix.com

Central Europe & Southern Africa:

Tel: + 49 2563 4858

France:

Tel: + 33 652 04 89 04

Americas, Spain & Portugal:

Tel: 888-887-4884 (toll free)
or +1 231-439-5000

Part Number	Description
SE03	Hydro-Probe SE - Standard Mode for normal digital or analogue connection
3010	Mounting Boss
3020	PTFE Gasket for mounting flange
0975	4m Sensor Cable with military specification sensor connector
0975-10m	10m Sensor Cable with military specification sensor connector
0975-25m	25m Sensor Cable with military specification sensor connector
0067	Terminal Box (IP66, 10 Terminals)
0116	24VDC Power Supply 30 watt for up to 4 Sensors
0049A	RS232-485 Adapter DIN rail mounting
0049B	RS232-RS485 Converter, 9 pin D-type to Terminal Block
SIMxx	USB Sensor Interface Module including cables and power supply
EAK01	Ethernet Adapter Kit
EPK01	Ethernet Power Kit
SEEW	4 Year extended warranty option

www.hydronix.com

SL0001 4.3.0